





Front Suspension:



RESET

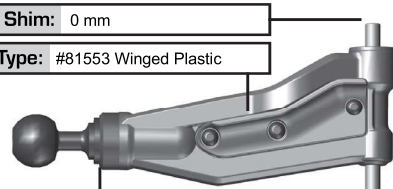
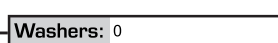
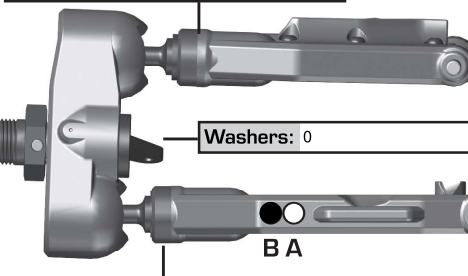
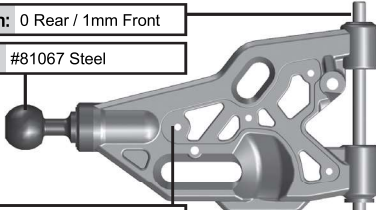

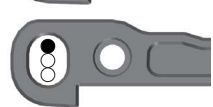
Ride Height: 23 mm	
Toe: Tierod Gap = 22.8 mm	Hex: #81079 +1
Anti-Roll Bar	
Size: 2.2 mm	
Gap: 2 mm	
Ackerman	
	
Steering Arm Plate: #81063 +2	
Drive Shaft: CVAs: <input checked="" type="checkbox"/> Universals: <input type="checkbox"/>	
Notes: 5 g ONG Front Chassis Weight	

Caster Shim: 0 mm	
Insert Type: #81553 Winged Plastic	
Upper Ball Type: #81067 Steel	
Upper Ball Shim: 1.4 mm (Thick)	
Washers: 0	
Lower Ball Shim: 0	

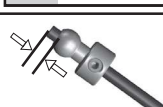
Wheelbase Shim: 0 Rear / 1mm Front	
Lower Ball Type: #81067 Steel	
Insert Type: None	
Insert Location: Top: <input type="checkbox"/> Bottom: <input type="checkbox"/>	
Upper Arm Mount:	
Arm Mount A:	
Arm Mount B:	

Rear Suspension:

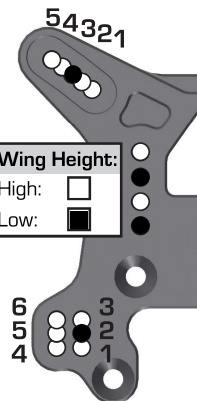
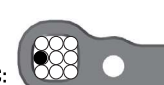
Ride Height: 28.5 mm	
Camber: Tierod Gap = 20.8 mm	Hex: #81079 +1
Anti-Roll Bar	
Size: 2.7 mm	
Gap: 2 mm	
Drive Shaft: CVAs: <input checked="" type="checkbox"/> Universals: <input type="checkbox"/>	
Chassis Brace:	
Ball: <input type="checkbox"/>	
Inserts: <input type="checkbox"/>	
Notes: Fuel Tubing For Chassis Brace Insert	
30 g ONG Rear Chassis Weight	

Hub Shim: 2.5 mm F / 2.5 mm R	Wheelbase Shim: 0 mm Front / 1 mm Rear
Wing Height: High: <input type="checkbox"/> Low: <input checked="" type="checkbox"/>	
Arm Mount C:	
Arm Mount D:	
Insert Type: None	
Insert Location: Top: <input type="checkbox"/> Bottom: <input type="checkbox"/>	

Electronics and Engine:

Radio: Sanwa Exses ZZ	
Receiver Battery: Sunpadow	
Throttle Servo: Sanwa PGS-XR	
Steering Servo: Sanwa PGS-XB	
EPA: Throttle: N/A % Brake: N/A %	
Brake Bias: 35F / 65R	D/R: N/A %
Engine: O.S. Ongaro Edition	Temp: N/A
Pipe: O.S. 2090 SC / 75 mm Header	Fuel: Runnertime 25%
Restrictor: 6.5	Glow Plug: O.S. P3
Notes:	

Differential:

	Front	Center	Rear
Fluid:	#5455 FT 10K	#5457 FT 30K	#5447 FT 5k
Gears:	HTC	HTC	HTC
Mass:	N/A	N/A	N/A
Notes:	#81463 44/13 Ring & Pinion Gear Set		

Clutch and Gearing:

Spur Gear: 46	Bell: 13
Shoes: ONG 3 x Aluminum Clutch	
Springs: ONG 3 x 1.0 mm	
Notes:	

Shocks:

	Front	Rear
Piston:	#81210 FT 8 x 1.2 mm Tapered, Angled	#81211 FT 8 x 1.3 mm Tapered, Angled
Fluid:	#5479 FT 47.5 wt	#5480 FT 50 wt
Bladder:	ONG	ONG
Rebound:	None	None
Spring:	Mugen 9.25T	Mugen 10.75T
Length:	104 mm	126 mm
Notes:		

Track Info:

Size: Small <input type="checkbox"/> Medium <input type="checkbox"/> Large <input type="checkbox"/> Extra Large <input checked="" type="checkbox"/>
Surface: Dirt <input checked="" type="checkbox"/> Carpet <input type="checkbox"/> AstroTurf <input type="checkbox"/> Multi Surface <input checked="" type="checkbox"/>
Traction: Low <input type="checkbox"/> Medium <input checked="" type="checkbox"/> High <input checked="" type="checkbox"/> Very High <input type="checkbox"/>
Moisture: Dry <input checked="" type="checkbox"/> Damp <input type="checkbox"/> Wet <input type="checkbox"/>
Condition: Indoor <input type="checkbox"/> Outdoor <input checked="" type="checkbox"/> Dusty <input checked="" type="checkbox"/> Hard Packed <input checked="" type="checkbox"/> Bumpy <input type="checkbox"/> Grooved <input checked="" type="checkbox"/> Smooth <input checked="" type="checkbox"/> Loamy <input type="checkbox"/>
Temperature: Ambient: 32° C / 90° F Track: 30° C / 85° F
Notes:

Tires:

Front Tire/Compound/Insert/Wheel:
AKA Double Down / Medium Long Wear / AKA Red / AKA
Rear Tire/Compound/Insert/Wheel:
AKA Double Down / Medium Long Wear / AKA Red / AKA
Notes:
Radio Tray Flex Assembly:
Transponder Mount: <input checked="" type="checkbox"/> None: <input type="checkbox"/>
Radio Tray Brace: <input checked="" type="checkbox"/>

Body and Wing:

Body: JConcepts S15
Nose Cone: JConcepts Kit
Rear Wing: #81554 Team Associated B4
Angle: 0° <input type="checkbox"/> 2° <input checked="" type="checkbox"/> 4° <input type="checkbox"/> Button: Flat <input checked="" type="checkbox"/> Fin <input type="checkbox"/>
Vent Holes: 8 mm Holes Across Wicker Lip
Weight:
Total Weight: N/A
Notes:

Vehicle Comments:

Notes: 2022-2023 IFMAR World Champion! #1371 FT Aluminum Clamping Throttle Servo Horn, 23T; #81012 Differential Front Outdrive, 17mm